

BASKET MOLD ASSEMBLY.

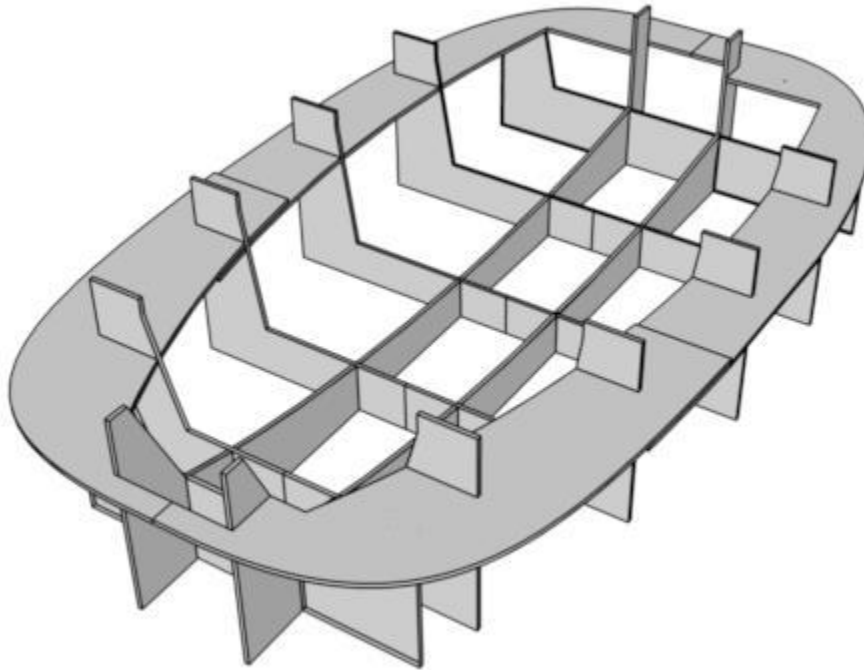

The sturdy basket mold is made from Meranti Light marine plywood 1/2" thick. All parts are notched for easy assembly. The mold goes together like a puzzle, there is nothing to measure.

The mold should be installed on a stable flat surface: floor, low table or some 2x4's on saw horses.

STEP 1: SIDES

The first step in the assembly is to drop the two side panels in place. No fasteners.

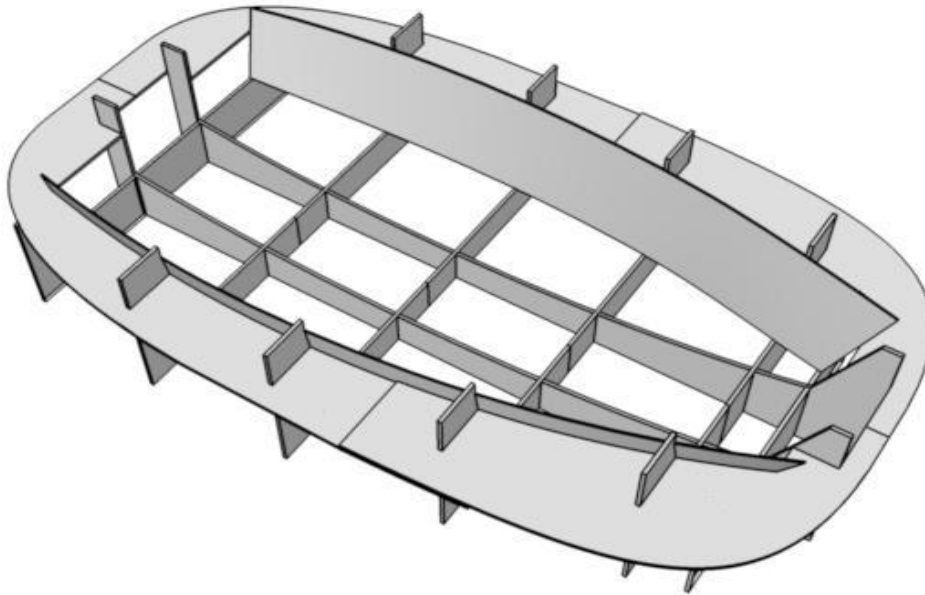

STEP 2: BOTTOM

Next, we push the bottom panel between the sides

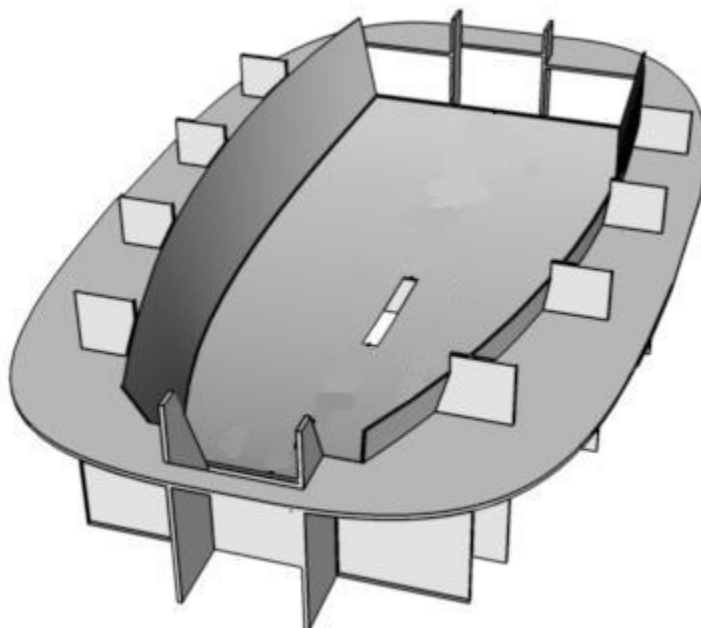

STEP 3: TRANSOMS

Then the two transoms between the sides.

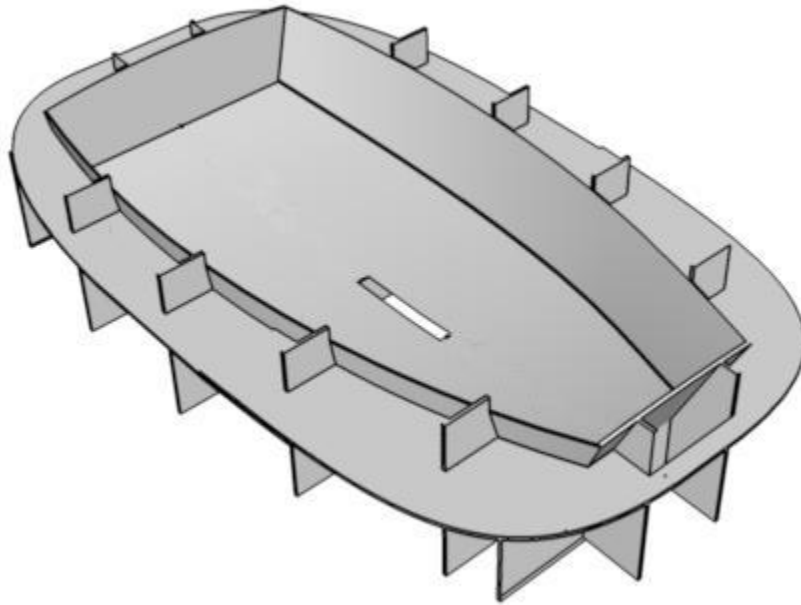

Still no fasteners. Note the cut for the dagger board trunk in the sole. The sole panel is supplied with a precise cut out.

STEP 4: FRAMES

To line up all the parts and block them in place, we use inside frames.

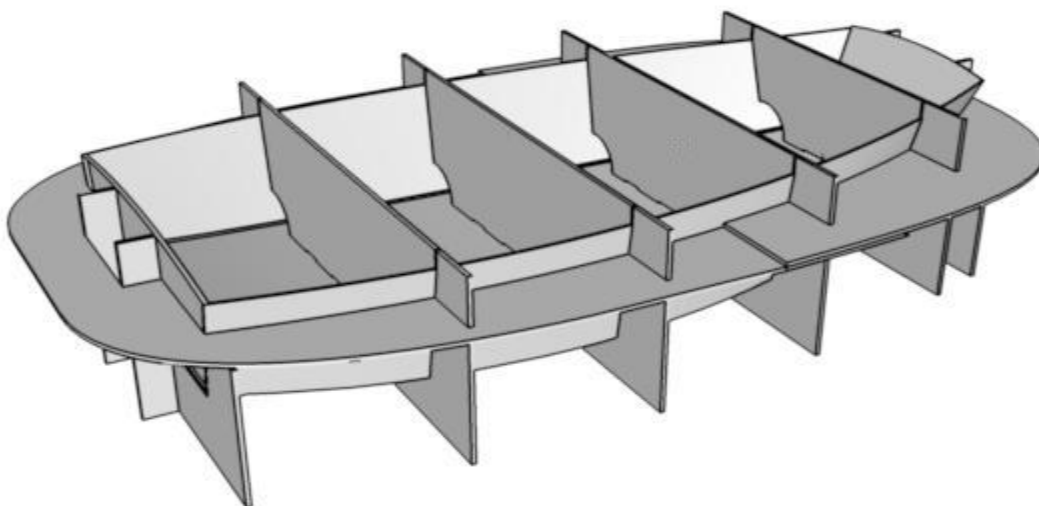

Those are parts of the hull kit. They line up exactly with the basket mold frames and will keep the hull panels precisely located during the fiberglass taping.

The inside frames have openings at the chine to allow the builder to install fiberglass tape in one piece.

STEP 5: INSIDE FIBERGLASS

At this stage, we tape all the inside: fillet, glass tape.

Once the resin is cured (overnight), we remove the inside frames.

STEP 6: INSIDE COMPONENTS

The next step is about installing the inside components: frames, dagger board trunk and mast step. To install those parts precisely, we use a jig (locator). That locator is included in your kit.

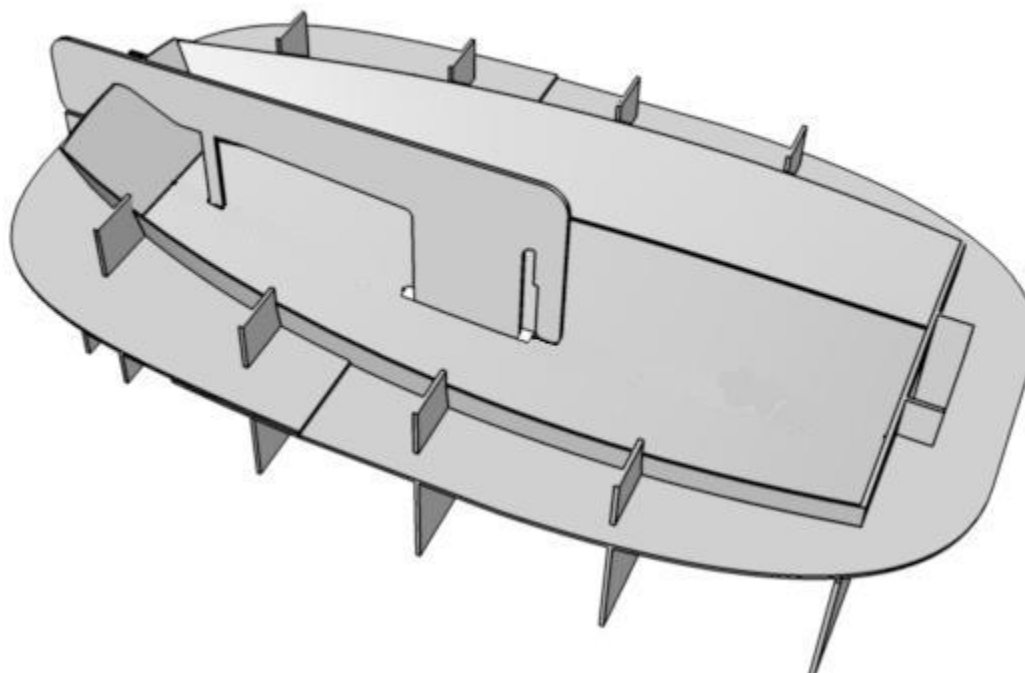

Forward, the locator will position the mast partner, mast frame and mast step.

In the middle, it will align the dagger board trunk and mid frame.

The locator extends through the slot in the bottom and is marked at the front to line up with the bow transom.

STEP 7: MORE INSIDE COMPONENTS

Start by assembling parts outside of the boat: mast step, dagger board trunk and mast frame assembly.

Refer to the hull building notes for details.

The mast step is made of several layers of plywood shaped like a staircase to follow the bottom curvature.

The mast frame and the mast partner are epoxy glued with a cleat in the inside corner.

The dagger board trunk is assembled as a box: two sides epoxy coated on all faces and glued.

The mid frame has a notch to receive a tab in the trunk and another notch to keep the mid frame at the proper height.

It is impossible to go wrong: the notches will position the trunk correctly against the mid frame.

Install all those parts loosely in the hull. The trunk goes through the slot in the hull, we will shave the outside flush later.

Cover the dagger board part of the locator with plastic sheet. This will keep it from sticking to the dagger board trunk. With the trunk extending through the hull, there be no spillage inside of the trunk but be safe and wrap the locator in plastic.

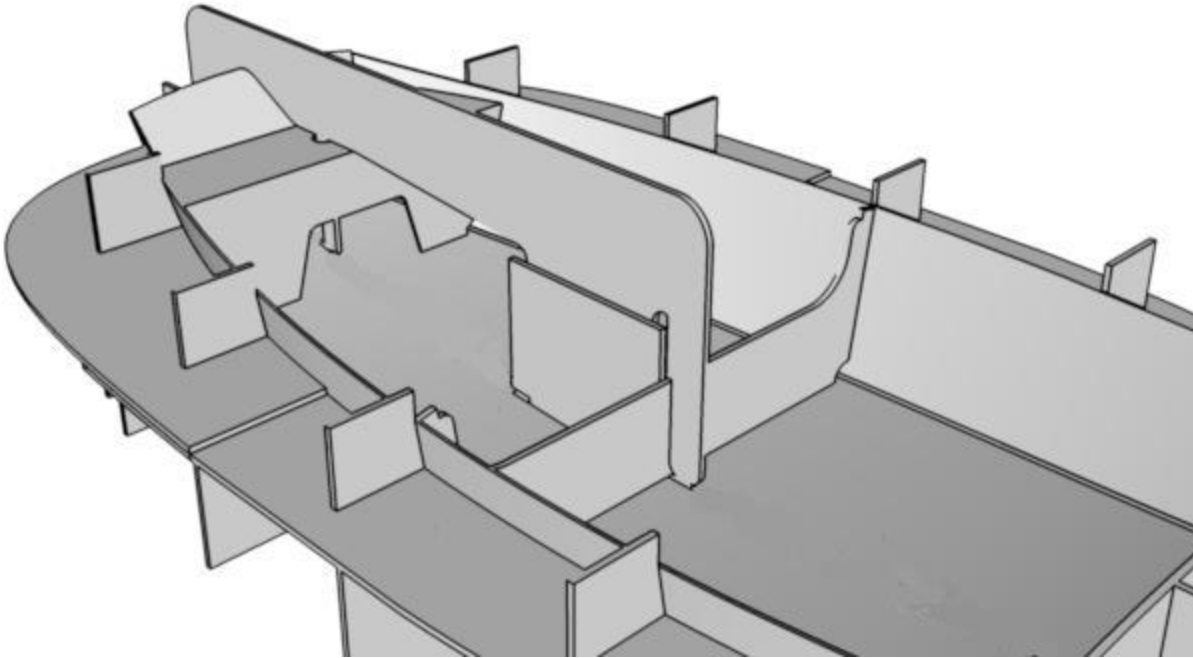

Other parts to install inside before removing the hull from the basket mold are:

- rubrail and coaming
- hog (= stringer)
- pads

Those parts, especially the hog and the rubrail/coaming assembly will stiffen the hull and preserve the shape. Without them the hull is flimsy, and the final dimensions may not be correct.

See the hull building notes about those parts.

STEP 8: REMOVE HULL FROM MOLD

Once all the parts are installed in the hull, epoxy cured, the hull can be pulled from the basket mold.

With the hull out of the mold, fiberglass the outside and proceed according to the hull building instructions.